

Indian Standard

**CODE OF PRACTICE FOR
DESIGN LOADS (OTHER THAN EARTHQUAKE)
FOR BUILDINGS AND STRUCTURES**

PART 4 SNOW LOADS

(Second Revision)

Fourth Reprint OCTOBER 1997

UDC 624.042.42: 006.7

© Copyright 1988

BUREAU OF INDIAN STANDARDS
MANAK BHAVAN, 9 BHADUR SHAH ZAFAR MARG
NEW DELHI 110002

Indian Standard

CODE OF PRACTICE FOR DESIGN LOADS (OTHER THAN EARTHQUAKE) FOR BUILDINGS AND STRUCTURES

PART 4 SNOW LOADS

*(Second Revision)***0. FOREWORD**

0.1 This Indian Standard (Part 4) (Second Revision) was adopted by the Bureau of Indian Standards on 9 November 1987, after the draft finalized by the Structural Safety Sectional Committee had been approved by the Civil Engineering Division Council.

0.2 A building has to perform many functions satisfactorily. Amongst these functions are the utility of the building for the intended use and occupancy, structural safety, fire safety; and compliance with hygienic, sanitation, ventilation and daylight standards. The design of the building is dependent upon the minimum requirements prescribed for each of the above functions. The minimum requirements pertaining to the structural safety of buildings are being covered in this Code by way of laying down minimum design loads which have to be assumed for dead loads, imposed loads, wind loads, snow loads and other external loads, the structure would be required to bear. Strict conformity to loading standards recommended in this Code, it is hoped, will not only ensure the structural safety of the buildings which are being designed and constructed in the country and thereby reduce the hazards to life and property caused by unsafe structures, but also eliminate the wastage caused by assuming unnecessarily heavy loadings. Notwithstanding what is stated regarding the structural safety of buildings, the application of the provisions should be carried out by competent and responsible structural designer who would satisfy himself that the structure designed in accordance with this code meets the desired performance requirements when the same is carried out according to specifications.

0.3 This Code was first published in 1957 for the guidance of civil engineers, designers and architects associated with the planning and design of buildings. It included the provisions for the basic design loads (dead loads, live loads, wind loads and seismic loads) to be assumed in the design of buildings. In its first revision in 1964, the wind pressure provisions were modified on the basis of studies of wind phenomenon and its effects on structures undertaken by the special

committee in consultation with the Indian Meteorological Department. In addition to this, new clauses on wind loads for butterfly type structures were included; wind pressure coefficients for sheeted roofs, both curved and sloping, were modified; seismic load provisions were deleted (separate code having been prepared) and metric system of weights and measurements was adopted.

0.3.1 With the increased adoption of the Code, a number of comments were received on the provisions on live load values adopted for different occupancies. Simultaneously live loads surveys have been carried out in America, Canada and other countries to arrive at realistic live loads based on actual determination of **loading** (movable and immovable) in different occupancies. Keeping this in view and other developments in the field of wind engineering, the Sectional Committee responsible for the preparation of this standard has decided to prepare the second revision in the following five parts:

Part 1 Dead Loads

Part 2 Imposed Loads

Part 3 Wind Loads

Part 4 Snow Loads

Part 5 Special Loads and Load Combinations

Earthquake load is covered in IS :1893-1984* which should be considered along with the above loads.

0.3.2 This part (Part 4) deals with snow loads on roofs of buildings.

The committee responsible for the preparation of the code while reviewing the available snow-fall data, felt the paucity of data on which to make specific recommendations on the depth of ground snow load for different regions effected by snow-fall, In due course the characteristic

*Criteria for earthquake resistant designing of **structures** (fourth **revision**).

snow load on ground for different regions will be included based on studies.

0.4 This part is based on ISO 4355-198 1 (E)

'Basis for design of structures — Determination of snow loads on roofs', issued by the International Organization for Standardization.

1. SCOPE

1.1 This standard (Part 4) deals with snow loads on roofs of buildings. Roofs should be **designed** for the actual load due to snow or for the **imposed** loads specified in Part 2 Imposed loads, whichever is more severe.

NOTE — Mountainous regions in northern parts of India are subjected to snow-fall.

In India, parts of Jammu and Kashmir (Baramulah District, Srinagar District, Anantnag District and Ladakh District); Punjab, Himachal Pradesh (Chamba, Kulu, Kinnaur District, Mahasu District, Mandi District, Sirmur District and Simla District); and Uttar Pradesh (Dehra Dun District, Tehri Garhwal District, Almora District and Nainital District) experience snow-fall of varying depths two to three times in a year.

2. NOTATIONS

μ (Dimensionless) — Nominal values of the shape coefficients, taking into account snow drifts, sliding snow, etc, with subscripts, if necessary.

l_i (in metres) — Horizontal dimensions with numerical subscripts, if necessary.

h_i (in metres) — Vertical dimensions with numerical subscripts, if necessary.

β_i (in degrees) — Roof slope.

s_o (in pascals) — Snow load on ground.

s_1 (in pascals) — Snow load on roofs.

3. SNOW LOAD IN ROOF (S)

3.1 The minimum **design** snow load on a roof area or any other area above ground which is subjected to snow accumulation is obtained by multiplying the snow load on ground, s_o by the shape coefficient μ , as applicable to the particular roof area considered.

$$s = \mu s_o$$

where

s = design snow load in Pa on plan area of roof,

μ = shape coefficient (see 4), and

s_o = ground snow load in Pa
(1 Pa = 1N/m²).

NOTE — Ground snow load at any place depends on the critical combination of the maximum depth of undisturbed aggregate cumulative snow-fall and its average density. In due course the characteristic snow load on ground for different regions will be included based on studies. Till such time the users of this standard are advised to **contact** either Snow and Avalanches Study Establishment (Defence Research and Development Organization) Manali (HP) or Indian Meteorological Department (IMD), Pune in the absence of any specific information for any location.

4. SHAPE COEFFICIENTS

4.1 General Principles

In perfectly calm weather, falling snow would cover roofs and the ground with a uniform blanket of snow and the design snow load could be **considered** as a uniformly distributed load. Truly uniform loading conditions, however, are rare and have usually only been observed in areas that are sheltered on all sides by high trees, buildings, etc. In such a case, the shape coefficient would be equal to unity.

In most regions, snow falls are accompanied or followed by winds. The winds will redistribute the snow and on some roofs, especially multi-level roofs, the accumulated drift load may reach a multiple of the ground load. Roofs which are sheltered by other buildings, vegetation, etc, may collect more snow load than the ground level. The phenomenon is of the same nature as that illustrated for multilevel roofs in 4.2.4.

So far sufficient data are not available to determine the shape coefficient in a statistical basis. Therefore, a nominal value is given. A representative sample of roof is shown in 4.2. However, in special cases such as strip loading, cleaning of the roof periodically by deliberate heating of the roof, etc, have to be treated separately.

The distribution of snow in the direction parallel to the eaves is assumed to be uniform.

4.2 Shape Coefficients for Selected Types of Roofs

4.2.1

Simple Flat and Monopitch Roofs

Simple Pitched Roofs (Positive Roof Slope)*

$0^\circ < \beta \leq 30^\circ$	$\mu_1 = 0.8$	$\mu_2 = \mu_1 = 0.8$
$15^\circ < \beta \leq 30^\circ$		$\mu_2 = 0.8 + 0.4 \left(\frac{\beta - 15}{15} \right)$ $\mu_1 = 0.8$
$30^\circ < \beta < 60^\circ$	$\mu_1 = 0.8 \left(\frac{60 - \beta}{30} \right)$	$\mu_2 = 1.2 \left(\frac{60 - \beta}{30} \right)$ $\mu_1 = 0.8 \left(\frac{60 - \beta}{30} \right)$
$\beta > 60^\circ$	$\mu_1 = 0$	$\mu_2 = \mu_1 = 0$

4.2.2

Simple or Multiple Pitched Roofs (Negative Roof Slope)

Two-Span or Multispan Roofs

$0^\circ < \beta < 30^\circ$	$\mu_2 = 0.8 \left(\frac{30 + \beta}{30} \right)$ $\mu_1 = 0.8$	$\mu_2 = 0.8 \left(\frac{30 + \beta}{30} \right)$ $\mu_1 = 0.8$
$30^\circ < \beta < 60^\circ$	$\mu_2 = 1.6$ $\mu_1 = 0.8 \left(\frac{60 - \beta}{30} \right)$	$\mu_2 = 1.6$ $\mu_1 = 0.8 \left(\frac{60 - \beta}{30} \right)$
$\beta > 60^\circ$	$\mu_2 = 1.6$ $\mu_1 = 0$	$\mu_2 = 1.6$ $\mu_1 = 0$

● For asymmetrical simple pitched roofs, each side of the roof shall be treated as one half of corresponding symmetrical roofs.

4.2.3 Simple Curved Roofs

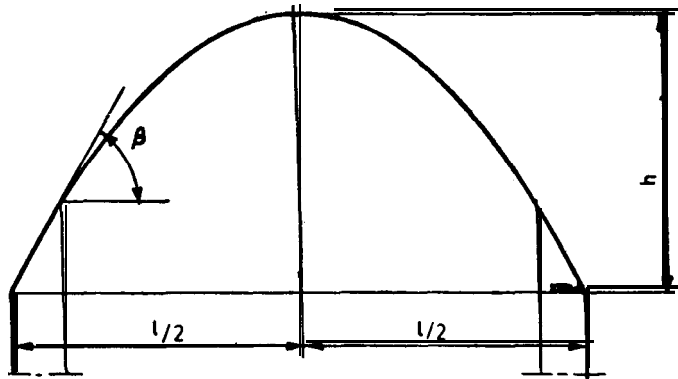

The following cases 1 and 2 must be examined:

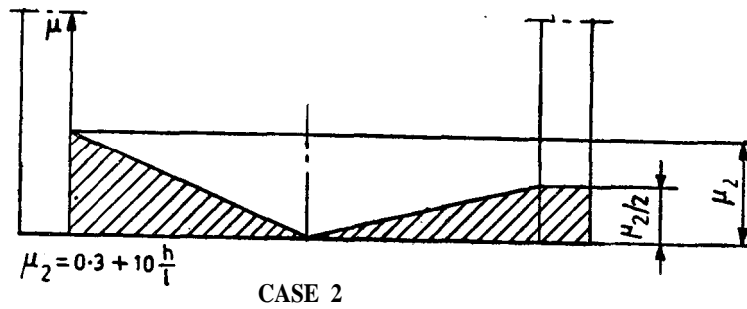
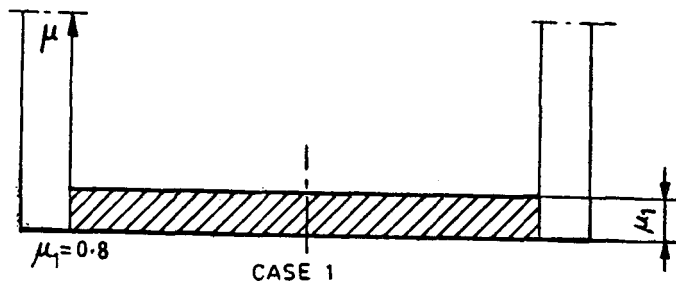

Restriction:

$$\mu_2 \leq 2.3$$

$$\mu = 0 \text{ if } \beta > 60^\circ$$

4.2.4 Multilevel Roofs*

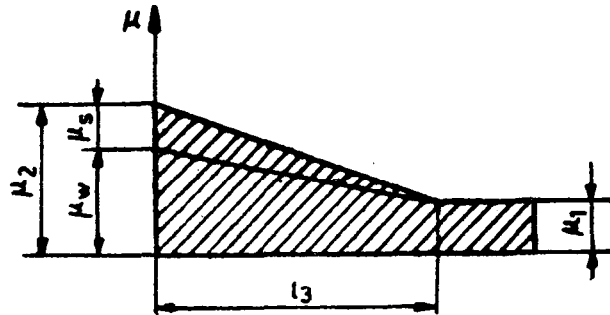
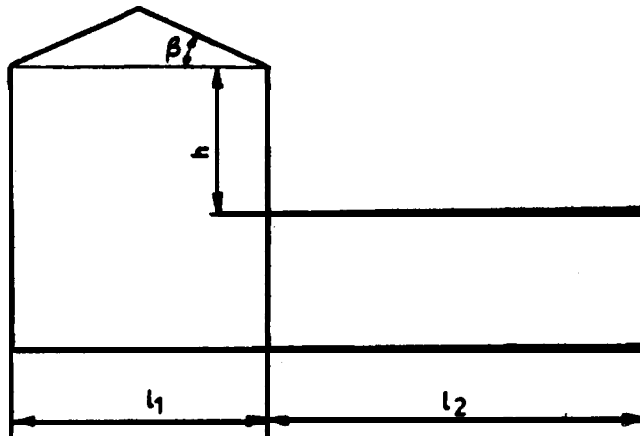

$$\mu_1 = 0.8$$

$$\mu_s = \mu_s + \mu_w$$

where

μ_s = due to sliding

μ_w = due to wind

$l_3 = 2h$ † but is restricted as follows:

$$5 \text{ m} < l_3 < 15 \text{ m}$$

$$\mu_w = \frac{l_1 + l_2}{2h} < \frac{kh}{s_0}$$

with the restriction $0.8 < \mu_w < 4.0$

where

h is in metres

s_0 is in kilopascals (kilonewtons per square metre)

$$k = 2 \text{ kN/m}^2$$

$\beta > 15^\circ$: μ_s is determined from an additional load amounting to 50 percent of the maximum total load on the adjacent slope of the upper roof†, and is distributed linearly as shown on the figure.

$$\beta < 15^\circ : \mu_s = 0$$

*A more extensive formula for μ_w is described in Appendix A.

†If $l_3 < l_s$, the coefficient μ is determined by interpolation between μ_1 and μ_s .

‡The load on the upper roof is calculated according to 4.2.1 or 4.2.2.

4.25 Complex Multilevel Roofs

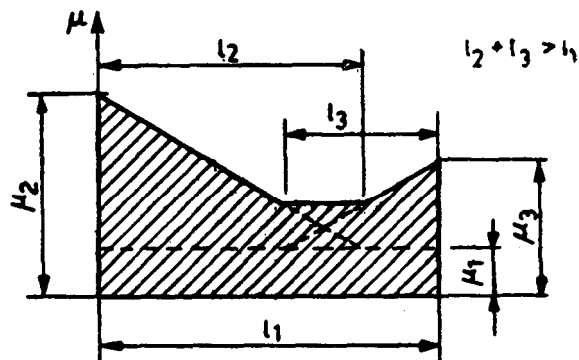
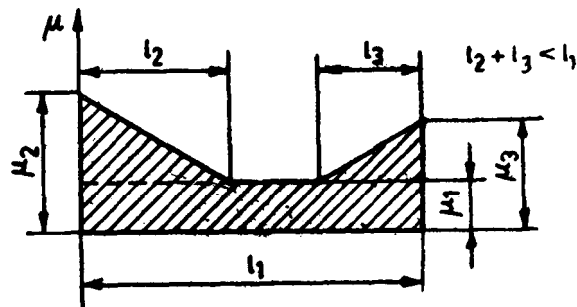
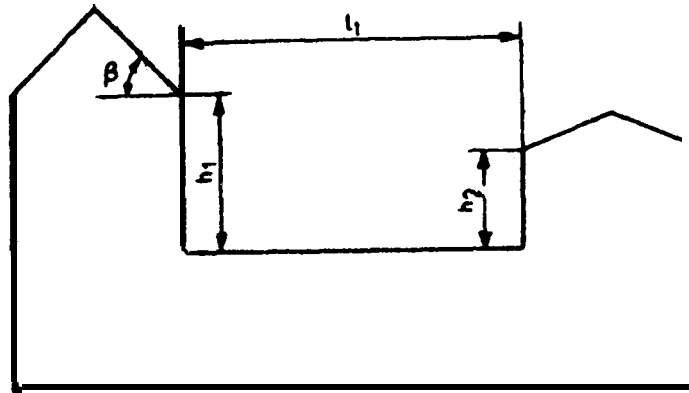

$$l_2 = 2h_1; l_3 = 2h_3; \mu_1 = 0.8$$

Restriction:

$$5 \text{ m} < l_2 < 15 \text{ m};$$

$$5 \text{ m} < l_3 < 15 \text{ m};$$

μ_s and μ_w ($\mu_s + \mu_w$), are calculated according to 4.2.1, 4.2.2 and 4.2.4.

4.2.6 Roofs with Local Projections and Obstructions

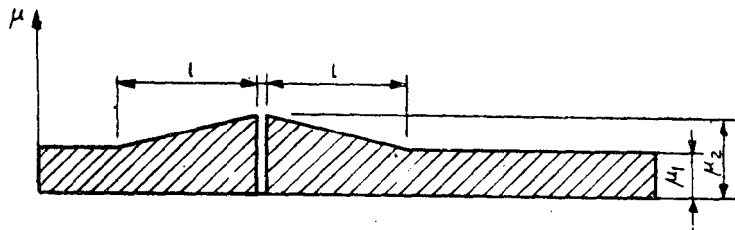
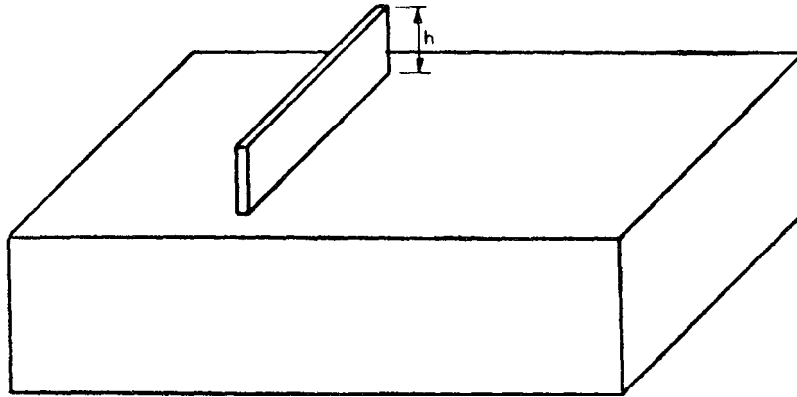

$$\mu_2 = \frac{kh}{s_0}$$

where

h is in metres

s_0 is in kilopascals (kilonewtons per square metre)

$k = 2 \text{ kN/m}^2$

$\mu_1 = 0.8$

$l = 2h$

Restrictions:

$0.8 \leq \mu_2 < 2.0$

$5 \text{ m} < l < 15 \text{ m}$

4.3 Shape Coefficients in Areas Exposed to Wind

The shape coefficients given in 4.2 and Appendix A may be reduced by 25 percent provided the designer has demonstrated that the following conditions are fulfilled:

- a) The building is located in an exposed location such as open level terrain with only scattered buildings, trees or other obstructions so that the roof is exposed to the winds on all sides and is not likely to become shielded in the future by obstructions higher than the roof within a distance from the building equal to ten times the height of the obstruction above the roof level;
- b) The roof does not have any significant projections such as parapet walls which may prevent snow from being blown off the roof.

NOTE — In some areas, winter climate may not be of such a nature as to produce a significant reduction of roof loads from the snow load on the ground. These areas are:

- a) Winter calm valleys in the mountains where sometimes layer after layer of snow accumulates on roofs without any appreciable removal of snow by wind; and
- b) Areas (that is, high temperature) where the maximum snow load may be the result of single snow-storm, occasionally without appreciable wind removal.

In such areas, the determination of the shape coefficients shall be based on local experience with due regard to the likelihood of wind drifting and sliding.

5. ICE LOAD ON WIRES

5.1 Ice loads are required to be taken into account in the design of overhead electrical-transmission and communication lines, over-head contact lines for electric traction, aerial masts and similar structures in zones subjected to ice formation. The thickness of ice deposit **around** may be taken to be between 3 and 10 mm depending upon the location of the structure. The mass density of ice may be assumed to be equal to **0.9 g/cm³**. While considering the wind force on wires and cables, the increase in diameter due to ice formation shall be taken into consideration.

APPENDIX A
(Clauses 4.2.4 and 4.3)

SHAPE COEFFICIENTS FOR MULTILEVEL ROOFS

A more comprehensive formula for the shape coefficient for multilevel roofs than that given in 4.2.4 is as follows:

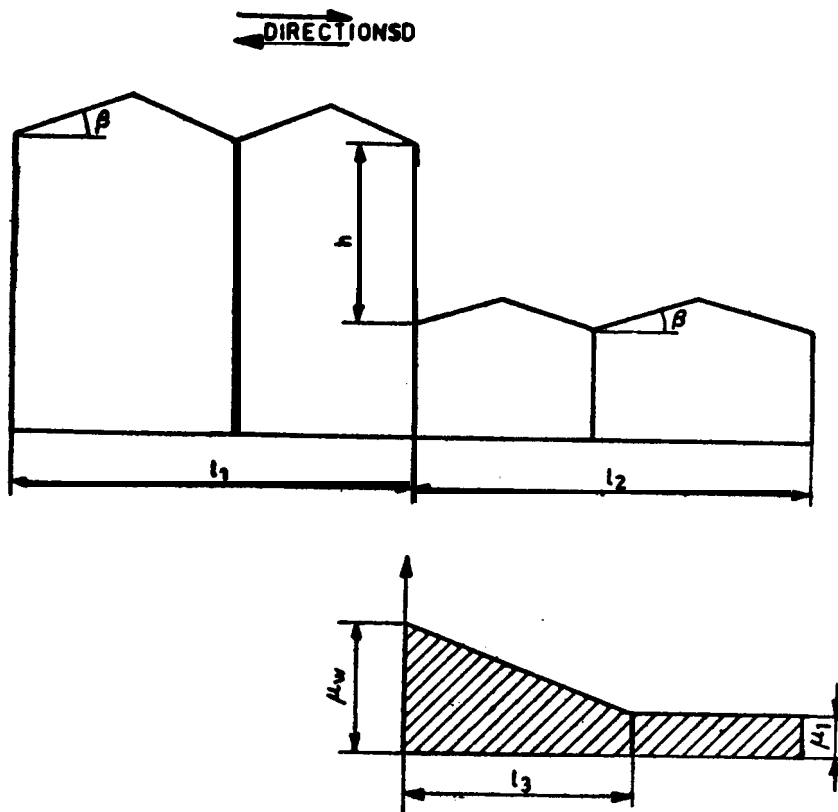

$$\mu_w = 1 + \frac{1}{h} (m_1 l_1 + m_2 l_2) (l_1 - 2 h)$$

$$\mu_1 = 0.8$$

$$l_3 = 2 h$$

(*h* and *l* being in metres)

Restriction :

$$\mu_w < \frac{kh}{s_0}$$

where

*s*₀ is in kilopascals (kilonewtons per square metre)

k is in newtons per cubic metre

$$l_3 < 15 m$$

Values of *m*₁ (*m*₂) for the higher (lower) roof depend on its profile and are taken as equal to:

$$0.5 \text{ for plane roofs with slopes } \beta < 20^\circ \text{ and vaulted roofs with } \frac{f}{l} < \frac{1}{8}$$

$$0.3 \text{ for plane roofs with slopes } \beta > 20^\circ \text{ and vaulted roofs with } \frac{f}{l} > \frac{1}{8}$$

The coefficients *m*₁ and *m*₂ may be adjusted to take into account conditions for transfer of snow on the roof surface (that is, wind, temperature, etc.).

NOTE — The other condition of loading also shall be tried.

Bureau of Indian Standards

BIS is a statutory institution established under the Bureau of *Indian Standards Act*, 1986 to promote harmonious development of the activities of standardization, marking and quality certification of goods and attending to connected matters in the country.

Copyright

BIS has the copyright of all its publications. No part of these publications may be reproduced in any form without the prior permission in writing of BIS. This does not preclude the free use, in the course of implementing the standard, of necessary detail, such as symbols and sizes, type or grade designations. Enquiries relating to copyright be addressed to the Director (Publication), BIS.

Review of Indian Standards

Amendments are issued to standards as the need arises on the basis of comments. Standards are also reviewed periodically; a standard along with amendments is reaffirmed when such review indicates that no changes are needed; if the review indicates that changes are needed, it is taken up for revision. Users of Indian Standards should ascertain that they are in possession of the latest amendments or edition by referring to the latest issue of 'BIS Handbook' and 'Standards Monthly Additions'.

Amendments Issued Since Publication

Amend No.	Date of Issue	Text Affected

BUREAU OF INDIAN STANDARDS

Headquarters:

Manak Bhavan, 9 Bahadur Shah Zafar Marg, New Delhi 110002
Telephones: 323 0131,323 33 75,323 94 02

Telegrams: Manaksanstha
(Common to all offices)

Regional Offices:

Central : Manak Bhavan, 9 Bahadur Shah Zafar Marg
NEW DELHI 110002

Telephone
323 76 17,323 38 41

Eastern : 1/14 C.I.T. Scheme VII M, V.I.P. Road, Maniktola
CALCUTTA 700054

{ 337 84 99,337 85 61
337 86 26,337 9120

Northern : SCO-335-336, Sector 34-A, CHANDIGARH 160022

{ 60 38 43
60 20 25

Southern : C.I.T. Campus, IV Cross Road, CHENNAI 600113

{ 235 02 16,235 04 42
235 15 19,235 23 15

Western : Manakalaya, E9 MIDC, Marol, Andheri (East)
MUMBAI 400093

{ 832 92 95,832 78 58
832 78 91,832 78 92

Branches : AHMADABAD. BANGALORE. BHOPAL. BHUBANESHWAR.
COIMBATORE. FARIDABAD. GHAZIABAD. GUWAHATI.
HYDERABAD. JAIPUR. KANPUR. LUCKNOW. NAGPUR.
PATNA. PUNE. THIRUVANANTHAPURAM.